

CMPE 650: Digital Systems Design

Project: Data Acquisition System

Goal: Design a four layer board to be fabricated at PCBExpress that digitizes an analog signal and produces a digital data stream. The basic architecture of the system is shown in the following Figure (red are optional components):

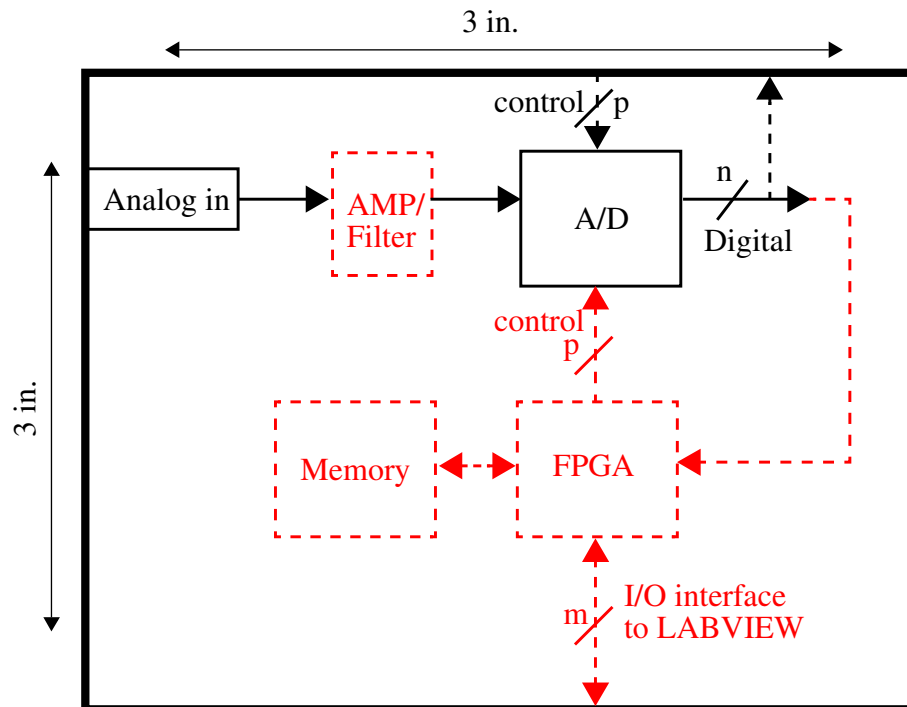

The minimum system must have at least an ADC, an analog input, digital output and control interface. Minimum system specification is 100 kS/s, 12-bit digital output and a voltage range of 0-5V. See <http://sine.ni.com/nips/cds/view/p/lang/en/nid/204053> for an example DAQ available from NI. As I mentioned in class, you can incorporate the controller and memory + other components onto the PCB (shown in red) or you may opt to use the FPGA cards that I have in my office, which will provide the FPGA and memory. You can interface the FPGA card with your PCB using a ribbon cable.

Your system must be controlled through LABVIEW, i.e. start/stop/transfer data. The chip that you use for the ADC is likely to be configurable, which also can be accomplished using LABVIEW. (Updates will be posted).

Be sure to visit www.pcbexpress.com to get the design rules for the 4-layer board you'll be fabricating.

Helpful references are "Low Level Measurements, 5th Edition" from Keithley Instruments and "Data Acquisition and Control Handbook, 1st Edition" also from Keithley (courtesy of Joy). These books can be ordered free of charge on the Keithley website.

Deadlines:

April 18th: Schematic of the system architecture that you plan to implement.

April 25th: Board layouts to be submitted to PCBExpress (due at the start of the lab)

May 9th: Final system demonstration.