

LANC-N-12

DIRECT INTERACTION EFFECTS IN EMP (U)

8 January 1971

This Effort Supported by  
DEFENSE ATOMIC SUPPORT AGENCY

under

NWER Subtask Code HC040

Work Unit Code: 04-Basic Contract  
14-Mod. No. 2

by

Conrad L. Longmire\*  
Los Alamos Nuclear Corporation

\*now at Mission Research Corporation  
P.O. Box 1356  
Santa Barbara, California 93101

SECTION 1  
INTRODUCTION

(U) For the electromagnetic pulse produced by nuclear explosions, a substantial amount of work has been applied to the calculation of that part of the EMP due to the interaction of the bomb gamma rays with the natural environment, e.g., the atmosphere or the ground surface. In EMP vulnerability studies of systems, the effect of the environmental EMP on the system is taken into account. When the system itself is exposed to the gamma rays, it may make its own contribution to the EMP to which it is subjected. This direct interaction EMP depends very much on the system, of course. In this note we shall discuss a few illustrative examples.

## SECTION 2.

### THE COMPTON CHARGING CURRENT

(U) Any material object exposed to a flux of gamma rays tends to become electrically charged. The quantity and sign of the charge depends on the gamma flux, of course, and also the geometry of the object and its surroundings. We shall consider a few simple cases.

#### 2.1 Compton Current in a Thick Medium

(U) Suppose we have, at some point in a material medium, a steady directed flux  $\vec{f}_\gamma$  of gamma ray energy, in  $\gamma$ -Mev/cm<sup>2</sup> sec. The gamma rays produce a directed flux of Compton recoil electrons. The ratio of the Compton electron flux to the gamma ray flux is given by the mean forward range of the electrons to the Compton mean free path of the gammas. This ratio is approximately independent of the type and density of the material, and is not strongly dependent on the gamma quantum energy. We may use as an approximate expression for the directed flux  $\vec{f}_e$  of Compton electrons.

$$\vec{f}_e \approx 0.005 \vec{f}_\gamma \quad (2-1)$$

This directed flux of Compton electrons constitutes an electric current density  $\vec{J}$ ,

$$\begin{aligned} \vec{J}(\text{ab amps/cm}^2) &= -\frac{e}{c} \vec{f}_e \approx -0.005 \frac{e}{c} \vec{f}_\gamma \\ &\approx -0.8 \times 10^{-22} \vec{f}_\gamma (\gamma\text{-Mev/cm}^2 \text{ sec}) \end{aligned} \quad (2-2)$$

(Note: 1 ab amp = 10 amps.) Here  $e$  is the magnitude of the electron charge (esu), and  $c$  is the velocity of light (cm/sec).

(U) This current leads to the production of magnetic and electric fields, depending on geometry. Usually, the electric field so produced drives a current of conduction electrons which tends to cancel the Compton current. In a good conductor, the conduction current will almost exactly cancel the Compton current; in an insulator, it will not.

(U) The equations above apply in the interior of a thick medium. Near the surface of the medium, results may be different; some distance may be required for the Compton flux to build up to the equilibrium value, Eq. (2-1), at the surface where the gamma flux enters the medium. This distance is approximately equal to the mean forward range (MFR) of the Compton recoil electrons. The MFR depends on the gamma energy and on the properties of the medium, but a representative value is

$$\text{MFR} \approx 0.15 \text{ gram/cm}^2 \quad (2-3)$$

Expressed in this way, the MFR is independent of density of the medium. Thus an object is Compton-thin or Compton-thick according to whether its projected mass per unit area is small or large compared with  $0.15 \text{ gram/cm}^2$ .

(U) Another thickness criterion relates to whether the object is thick enough to absorb an appreciable fraction of the gamma flux. A typical energy absorption mass for gamma rays is

$$m_\gamma \approx 30 \text{ grams/cm}^2 \quad (2-4)$$

Thus an object will be gamma-thin or gamma-thick if its projected mass per unit area is small or large compared with  $30 \text{ grams/cm}^2$ . For a gamma-thick object, the gamma flux emerging from the back side will be much less than that entering the front side.

(U) Since gamma energy is absorbed in passing through matter, the Compton current density, Eq. (2-2), has finite divergence in the body of the medium. A beam of gamma energy flowing in the x-direction is attenuated as

$$f_{\gamma} \sim \exp(-\rho x/m_{\gamma}) \quad (2-5)$$

where  $\rho$  is the mass density (gm/cm<sup>3</sup>) of the medium. Thus charge density  $q$  (esu/cm<sup>3</sup>) is deposited at a rate

$$\begin{aligned} \frac{dq}{dt} &= -c\nabla \cdot \vec{J} = -0.005 \frac{e_0}{m_{\gamma}} \bar{F}_{\gamma} \\ &= -2.4 \times 10^{-12} \frac{\rho}{m_{\gamma}} \bar{F}_{\gamma} \end{aligned} \quad (2-6)$$

Here  $\bar{F}_{\gamma}$  is the gamma flux integrated over all directions, and is equal to  $f_{\gamma}$  for a mono-directional beam. In a good conductor this volume-deposited charge quickly moves to the surface. In an insulator it will be stuck as a volume charge unless breakdown occurs. This volume discharge in insulators under irradiation has been observed, and forms very intricate patterns.

## 2.2 Charge Collected by a Solid Object in Air

(U) Suppose we have a solid object surrounded by air, with the whole region subject to a gamma flux. The relation (2-2) applies both in the solid object and in the air, independent of the mass density, provided the Compton MFR is determined by mass stopping power in both regions. (The reason no density factor occurs in Eq. (2-2) is that the source density of Comptons is proportional to  $\rho$  whereas RMF is proportional to  $\rho^{-1}$ .) Thus  $\vec{J}$  is continuous at the surface of the object, and to obtain the rate of collection of total charge  $Q$  by the object, we simply integrate Eq. (2-6) over the volume of the object

$$\frac{dQ}{dt} \text{ (esu/sec)} = - \frac{2.4 \times 10^{-12}}{m_{\gamma}} \int \rho \bar{F}_{\gamma} dV \quad (2-7)$$

If the object is gamma-thin (in the direction of the gamma flux), the variation of  $\bar{F}_{\gamma}$  over the volume can be neglected, with the simple result

$$\frac{dQ}{dt} = -2.4 \times 10^{-12} \frac{M \bar{F}_{\gamma}}{m_{\gamma}} \quad (\text{gamma-thin}) \quad (2-8)$$

Here  $M$  (grams) is the total mass of the object. Thus the charging rate is proportional to the mass of the object if it is gamma-thin. If the object is gamma thick, Eq. (2-7) must be used with the attenuation of  $\bar{F}_\gamma$  taken into account. If the object is several  $m_\gamma$ 's thick, the integral can be done approximately, with the result

$$\frac{dQ}{dt} = -2.4 \times 10^{-12} \bar{F}_\gamma S \quad (\text{gamma-thick}) \quad (2-9)$$

Here  $\bar{F}_\gamma$  is the flux on the exposed side of the object and  $S$  is the projected area of the object.

(U) Note that the charge accumulated is negative in this case.

### 2.3 Charge Collected by an Object in Vacuum

(U) Let us now inquire what happens as we let the density of the surrounding air decrease toward zero. As long as the Compton MFR is determined by mass stopping power, Eq. (2-2) remains valid, and so do the results of Section 2.2. However, at sufficiently low density, other mechanisms come to limit the mean forward excursion of the Compton recoil electrons. One such limiting effect comes from the radial electric field that builds up in the air as a result of the outward flow of Compton electrons. Another is the bending of the Compton electron trajectories into Larmor orbits by the geomagnetic field. The latter effect limits the excursion of the electrons, in directions across the magnetic field, to about 100 meters. At altitudes above 30 km, the geomagnetic limiting dominates mass stopping power. Thus, as we go to higher altitudes, the Compton current in the air falls below Eq. (2.2), proportionally to the air density. The Compton current entering the object from the air, on the front side, will then become negligible compared with that leaving the object on the back side, if the object is Compton-thick. The total charging rate of the object is then determined by the Compton current leaving the back side,

$$\frac{dQ}{dt} = +2.4 \times 10^{-12} \bar{F}_\gamma S \quad (2-10)$$

In this case the charge accumulated is positive.

#### 2.4 Effect of Conduction Current

(U) Often, in EMP problems, the Compton current leads to an electric field, which drives a conduction current nearly cancelling the Compton current. This occurs in air, for example, at distances not too large from the burst. The air conductivity results from the many secondary electrons made by each Compton electron in slowing down.

(U) One might expect net charging rates of objects to be reduced by the conduction current, since it tends to cancel the Compton current. Actually, it can increase the net charging rate, as in the following example.

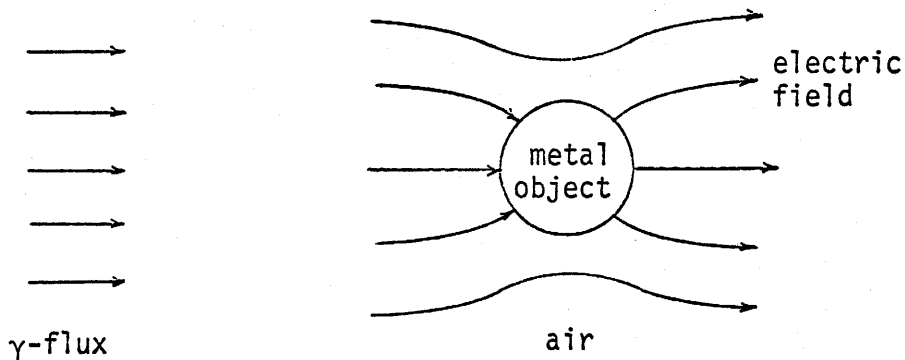

(U) Figure 1. Metal object in air exposed to gamma flux. (U)

In this example, Compton electrons are driven from left to right by the gamma flux, both in the air and in the object. As a result of the Compton flux an electric field builds up in the air, as indicated in Figure 1.

(U) The direct Compton current leads to negative charging of the object, according to Eq. (2-8) or (2-9); more Compton electrons are driven into the front than out of the back. The conduction electrons flow in the direction opposite to the electric field. Thus conduction electrons flow into the object at the back. They would also flow out of the object at the front if they could get out of the metal surface. However, the only electrons that can get out of the front surface are the back-splash electrons (secondary emission) produced by entering Compton electrons. If the coefficient of secondary emission is small compared with unity, there may be fewer conduction electrons leaving the front surface than entering the back surface. Thus the conduction current too can lead to negative charging of the object.

(U) When the object is charged sufficiently negative, it will repel further conduction electrons. The electric field pattern will then be as sketched in Figure 2.

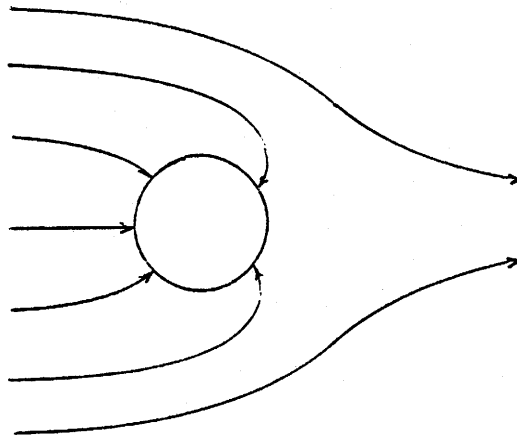

(U) Figure 2. Alteration of electric field by negative charge on object. (U)

(U) In addition, positive ion conductivity reduces the negative charging effect. A boundary layer forms in the air near the metal surface, on the front side, in which there are more positive ions than electrons, and the electric field is enhanced, increasing the positive ion current.



(U) To take account of these effects and solve Maxwell's in a medium (air) of changing conductivity obviously presents a formidable problem, which probably would be best approached by computer techniques. We shall attack a simple example analytically below. First, however, we shall discuss typical magnitudes of the currents.

SECTION 3  
TYPICAL MAGNITUDES

(U) We shall take as a typical example a one-megaton explosion which emits two kilotons of prompt gamma energy. Thus the total number of  $\gamma$ -Mev produced is

$$N(\gamma\text{-Mev}) \approx 5 \times 10^{25} \quad (3-1)$$

(The number of  $\gamma$ -rays is also approximately equal to  $5 \times 10^{25}$ , since the average energy per gamma is of the order of 1 Mev.) We shall assume that the gammas are emitted in a time interval

$$T \approx 2.5 \times 10^{-8} \text{ second} \quad (3-2)$$

At a distance  $R$  (in km) the average flux of gamma energy is

$$f_{\gamma} \frac{\gamma\text{-Mev}}{\text{cm}^2 \text{ sec}} = 2 \times 10^{23} \frac{e^{-R/\lambda}}{4\pi R^2} \quad (3-3)$$

Here  $\lambda$  is the absorption length of the gammas. In air at sea level,

$$\lambda = 0.23 \text{ km} \quad (\text{sea level}) \quad (3-4)$$

At higher altitudes,  $\lambda$  is inversely proportional to the air density. From Eq. (2-2), the Compton current density is

$$\begin{aligned} J &= -16 \frac{e^{-R/\lambda}}{4\pi R^2} && \text{ab amps/cm}^2 \\ &= -1.6 \times 10^6 \frac{e^{-R/\lambda}}{4\pi R^2} && \text{amps/m}^2 \end{aligned} \quad (3-5)$$

(U) At altitudes above 50 km,  $\lambda$  is so long that the attenuation factor  $e^{-R/\lambda}$  can usually be replaced by unity. Then, for example, the Compton current ejected from a missile of area  $10 \text{ m}^2$  at a distance of 100 km from the burst is

$$I \approx -130 \text{ amps} \quad (3-6)$$

At the end of the pulse, the total charge on the missile is

$$Q = -I \times T = 3.2 \times 10^{-6} \text{ coulombs} \quad (3-7)$$

The capacitance of such a missile with respect to space is about

$$C \approx 300 \text{ } \mu\text{f} \quad (3-8)$$

Thus the potential of the missile with respect to space is about

$$V = Q/C \approx 10^4 \text{ volts} \quad (3-9)$$

The electric field (a few thousand volts/meter) going with this potential will affect any antenna the missile may have. In addition, a sizeable fraction of the current  $I$  above will flow on the surface of the missile, as surface charges form to accommodate the electric field, and these surface currents will couple into exposed control cabling.

(U) The air surrounding the missile is partially ionized by the gamma rays, forming a plasma. The missile charge and electric field are eventually dissipated by this plasma, at a rate determined by the plasma frequency or the plasma resistivity.

(U) For a near-surface burst example, let us take a point at 1 km from the burst. Then from Eq. (3-5), the Compton current density is

$$J = -1.6 \times 10^3 \text{ amps/m}^2 \quad (3-10)$$

Actually, at this distance the prompt gamma pulse is broadened somewhat by scattering in the air, so that the peak current is somewhat less than this. The time integral of the current

$$JT = -4 \times 10^{-5} \text{ Coulomb/m}^2 \quad (3-11)$$

is correct, however. A gamma-thin object exposed to this flux collects, per kilogram of its mass, a current

$$I = -5.3 \text{ amps/kg} \quad (3-12)$$

and a total charge

$$Q = -1.3 \times 10^{-7} \text{ Coulomb/kg} \quad (3-13)$$

#### SECTION 4

#### EXAMPLE: VERTICAL DIPOLE AND SURFACE BURST

(U) In this section we shall consider, as a simple example, a short vertical dipole antenna which is constructed so as to be fairly hard to blast. Figure 3 is a sketch of the essentials of the antenna. We do

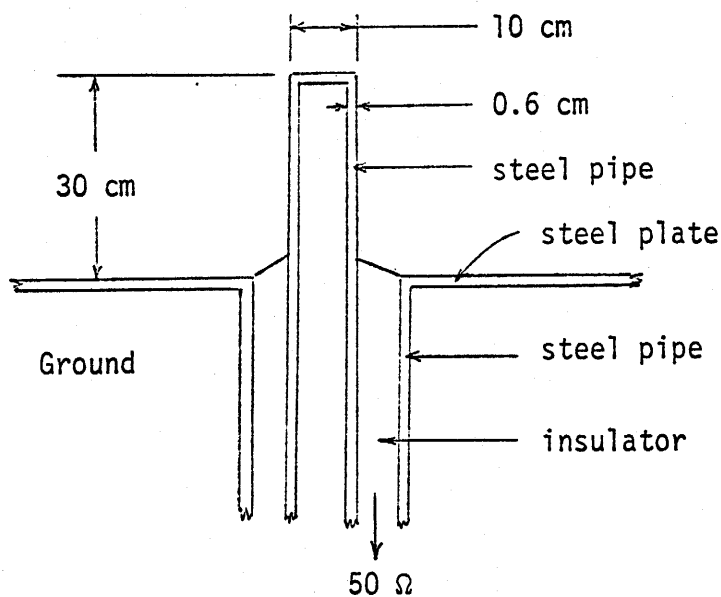

(U) Figure 3. Sketch of blast-hardened antenna. (U)

not mean to suggest that this sketch represents any existing antenna, but that EMP effects on this model are illustrative of effects on a class of real antennas.

(U) In our model the antenna is a hollow steel pipe, which emerges from the ground through a larger pipe, with the latter connected to a

steel ground plane. We imagine the impedance looking down into the coaxial transmission line, formed by the pipes, is a simple 50 ohms.

(U) We assume that a one-megaton surface burst occurs at a distance of 1 km from the antenna. The antenna will then be subjected to a peak over-pressure of about 120 psi, and a peak dynamic pressure of about 140 psi, which it should be able to survive. The EMP arrives before the blast wave, in any case.

For the hypothetical EMP environment to be used in our example, we need not be too concerned with accuracy. We shall use the curves of Figure 4 for the horizontal Compton current density  $J$ , the vertical electric field  $E$ , and the air conductivity  $\sigma$  in the neighborhood of the antenna. The conduction current density  $\sigma E$  in the air is also graphed in the figure.

(U) There is also a horizontal electric field, in general, which should be taken into account in an accurate treatment. We shall neglect it here on the grounds, first, that the highly conducting steel ground plane makes it small, and second, that the antenna is less sensitive to horizontal  $E$  than vertical  $E$ .

(U) The presence of the antenna will, of course, distort the electric field from vertical in the neighborhood of the antenna. The rate at which the distortion can occur is limited by the air conductivity. The skin depth at time  $t$  (sec) after application of a step is ( $\sigma$  in mho/meter)

$$\delta \text{ (meters)} = 1.26 \times 10^3 \sqrt{\frac{t}{\sigma}} \quad (4-1)$$

Using  $t = 1 \times 10^{-8}$  second and the peak  $\sigma = 0.35$  mho/meter, we find

$$\delta \approx 0.7 \text{ meter} \quad (4-2)$$

Since this is more than twice the height of the antenna, we may assume that the electric field is completely relaxed to the static configuration.

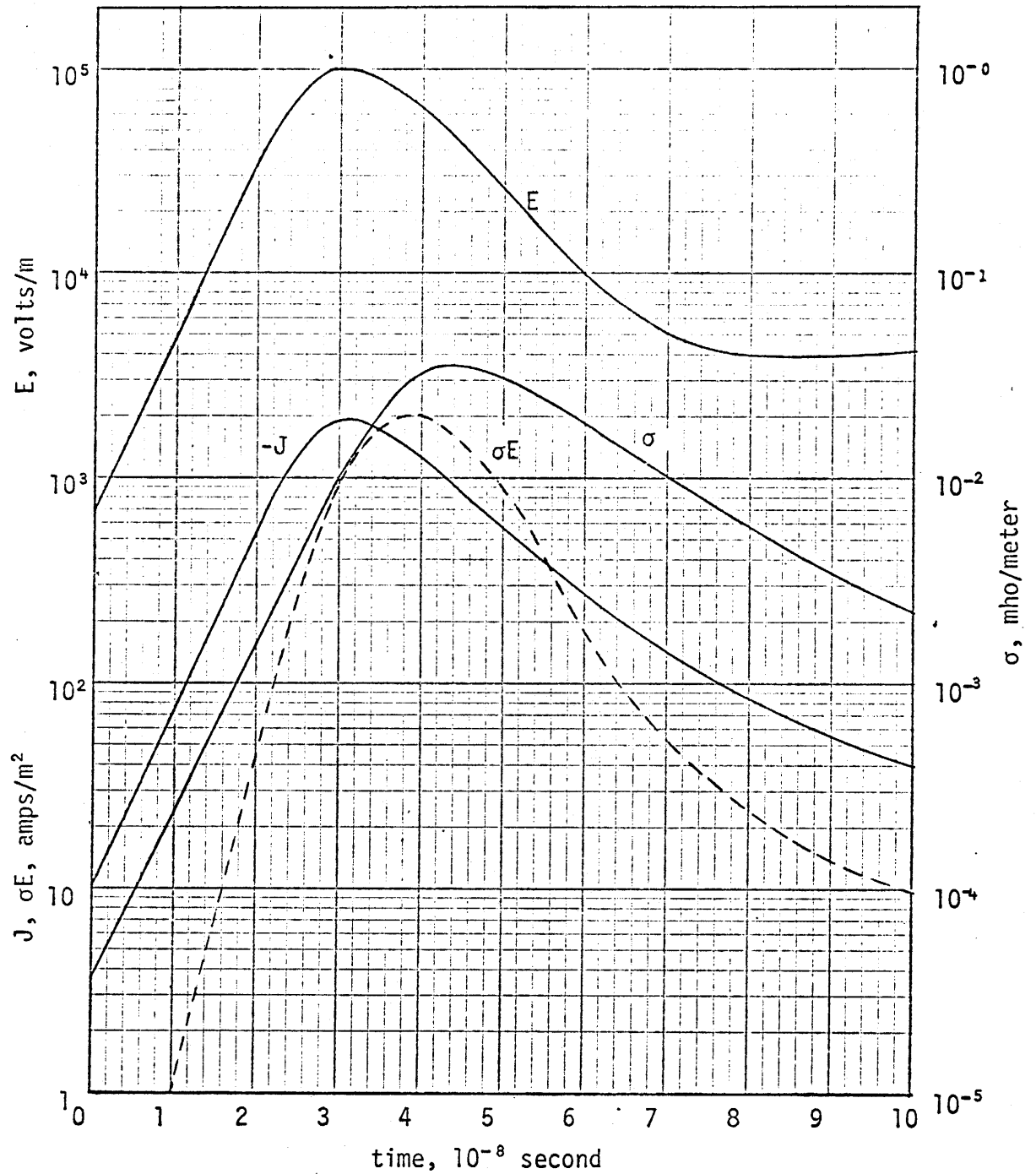

(U) Figure 4. Vertical electric field  $E$ , Compton current density  $J$ , air conductivity  $\sigma$ , and conduction current density  $\sigma E$ , as functions of time. (U)

(U) We shall now construct an equivalent circuit, based on the approximations stated above, for use in calculating the response of the antenna. The electric field pattern near the antenna will be similar to that sketched in Figure 5. There is obviously capacitive coupling from the free field

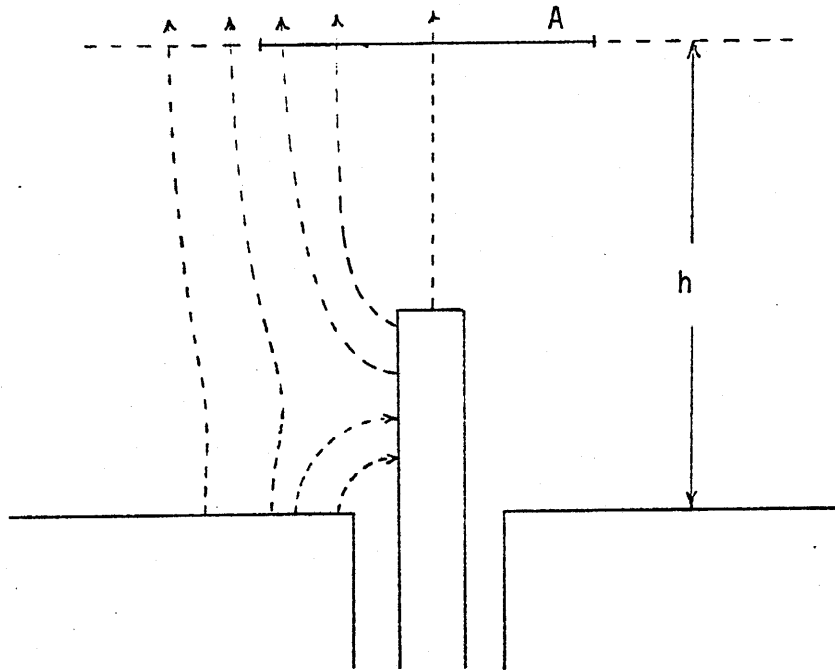

(U) Figure 5. Sketch of electric field pattern. (U)

to the dipole stub, and also a capacitance between the stub and the ground plane. In addition, the Compton current couples directly into the stub. We therefore have the equivalent circuit shown in Figure 6.

(U) There are two generators in the problem. The Compton current generator has high "internal" impedance; the Mev type Compton electrons are little affected by kev potentials which the stub will acquire. The current  $I_c$  is negative, and since the stub is gamma thin

$$I_c = J \left( \frac{\text{amps}}{\text{m}^2} \right) \times \frac{M(\text{kg})}{m_\gamma(\text{kg/m}^2)} \quad (4-3)$$



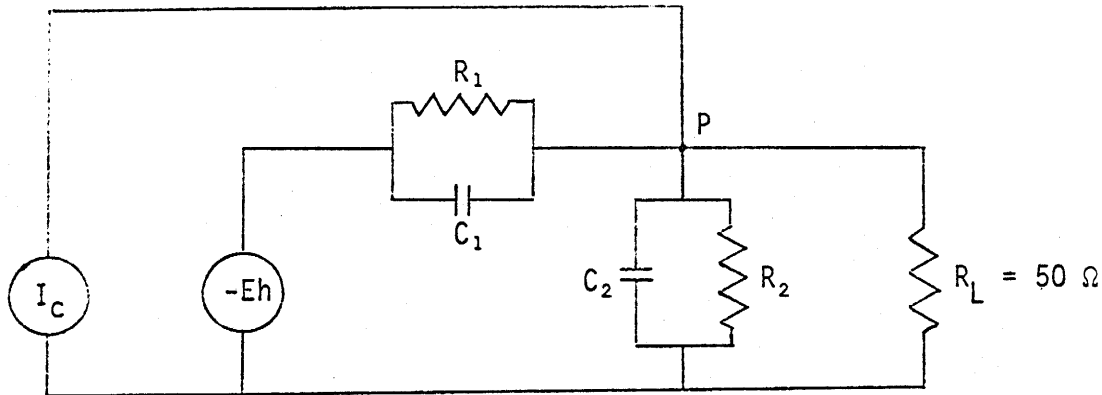

(U) Figure 6. Equivalent circuit. (U)

Here  $M$  is the mass of the stub, about 4 kg, and  $m_\gamma \approx 300 \text{ kg/m}^2$  is the absorption mass of the gammas. Thus

$$I_C(\text{amps}) \approx 0.013 J_C (\text{amps/m}^2) \quad (4-4)$$

(U) The other generator is the free electric field. Since  $E$  is a field, volts/meter, instead of a voltage, it cannot appear alone in the equivalent circuit. We imagine a horizontal conducting plane to be placed in the air at a height  $h$  large compared with the antenna. The presence of the plane will then not affect the current drawn by the antenna. The capacitance  $C$ , is then determined by the area  $A$  (indicated in Figure 5) of this plane over which field lines attach to the antenna if the latter is grounded. In MKS units,

$$C_1(\text{farads}) = \frac{1}{9 \times 10^9} \frac{A(\text{m}^2)}{4\pi h(\text{m})} \quad (4-5)$$

$R_1$  is also simply related to the area  $A$  and height  $h$ ,

$$\frac{1}{R_1(\text{ohms})} = \frac{\sigma(\text{mho/m}) A(\text{m}^2)}{h(\text{m})} \quad (4-6)$$

These results illustrate the universal relation between the resistance and the capacitance between objects immersed in a conducting medium

$$RC(\text{ohm-farad=sec}) = \frac{1}{36\pi 10^9 \sigma} = \frac{0.884 \times 10^{-11}}{\sigma(\text{mho/m})} \quad (4-7)$$

(U) The area  $A$  could be determined by solving a problem in electrostatics. Here we shall simply make the guess that

$$A \approx 0.10 \text{ m}^2 \quad (4-8)$$

so that

$$C_1 \approx \frac{0.9}{h} \text{ } \mu\text{f} \quad , \quad R_1 \approx \frac{10h}{\sigma} \text{ ohms} \quad (4-9)$$

(U) We should now pass to the limit  $h \rightarrow \infty$ , so that  $Eh \rightarrow \infty$ ,  $C_1 \rightarrow 0$ , and  $R_1 \rightarrow \infty$ . Thus the impedance of this source is also very large, and we may regard this source as injecting a current  $I_1$  into the junction  $P$  of Figure 6,

$$\begin{aligned} I_1 &= -\frac{Eh}{R_1} + C_1 \frac{d}{dt} (-Eh) \\ &\approx -\frac{\sigma E}{10} - 0.9 \times 10^{-12} \frac{dE}{dt} \end{aligned} \quad (4-10)$$

The total current fed into the junction  $P$  by the two sources is the sum of  $I_c$  and  $I_1$ .

(U) For the capacitance  $C_2$  between stub and ground we shall guess

$$C_2 = 10 \text{ } \mu\text{f} \quad (4-11)$$

From Eq. (4-7) we then find  $R_2$ ,

$$R_2 = \frac{0.9}{\sigma} \text{ ohms} \quad (4-12)$$

(U) The capacitance  $C_2$  can be neglected in our problem, because the time constant of  $C_2$  in parallel with  $R_2$  and  $R_L$  is very short. Taking  $R_L$  alone, we find

$$R_L C_2 = 5 \times 10^{-10} \text{ sec} \quad (4-13)$$

which is small compared with the rise and fall times of the signals. Thus the total load into which the current  $I_C + I_1$  flows may be taken as  $R_2$  and  $R_L$  in parallel, and the voltage  $V$  fed into the transmission line is

$$V = (I_C + I_1) \frac{R_2 R_L}{R_2 + R_L} \quad (4-14)$$

(U) In Figure 7, various terms in this equation are graphed as functions of time.  $I_{11}$  is the resistive part of  $I_1$  (first term on the right in Eq. (4-10)), and  $I_{12}$  is the reactive part (last term in Eq. (4-10)).  $R_T$  is the net resistance of  $R_2$  and  $R_L$  in parallel. The peak value of the voltage fed into the line is about 4500 volts. The peak power fed in is about 0.4 megawatts. The total energy fed in is about  $6 \times 10^{-3}$  joules.

(U) The ratios of the various currents will obviously depend on the antenna design, distance from the burst, and rise rate of the gamma flux. In addition, at higher gamma exposure, the skin depth in the air will not be large compared with the antenna dimensions, so that the effective collection area  $A$  will become a function of time. In the latter case, solution of the whole problem by computer techniques may be desirable.

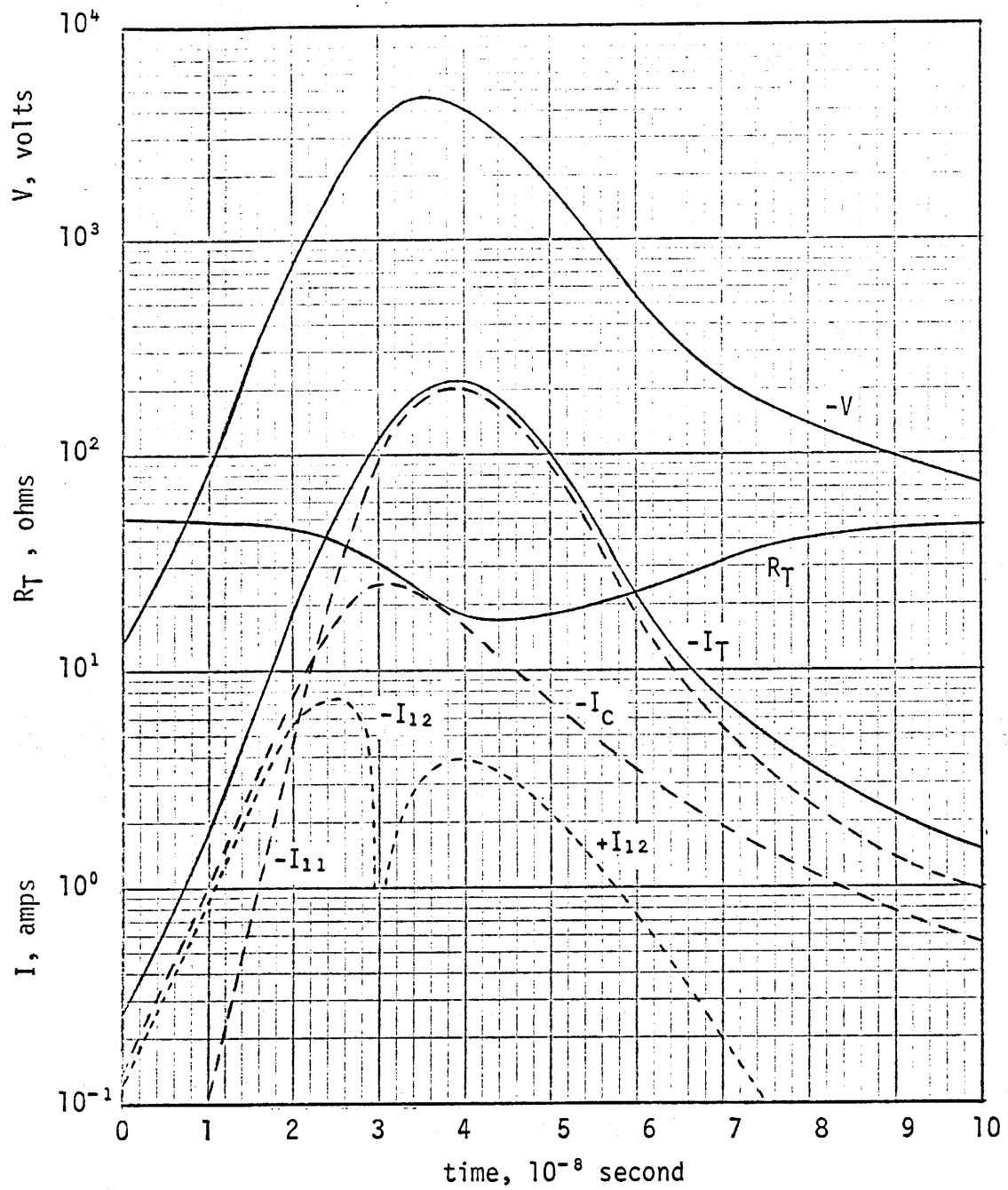

(U) Figure 7. Various currents  $I$ , total resistance  $R_T$ , and voltage  $V$  as functions of time.

SECTION 5  
BOUNDARY LAYERS

(U) In the example above, the fact that the conductance ( $1/R_2$ ), from the stub through the air to ground, limits the negative voltage acquired by the stub, means that an appreciable current of electrons flows from the stub through the air to the ground. Thus the question is again raised, whether conduction electrons can get out of the metal stub into the air. The importance of this question is somewhat reduced by the fact that there is capacitive coupling from the metal through a boundary layer that forms in the air near the metal surface.

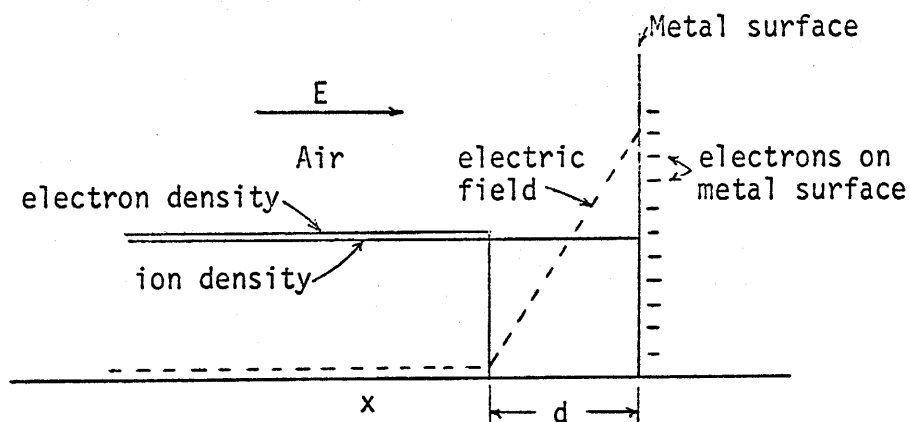

Figure 8. Model of boundary layer.

(U) Referring to Figure 8, we assume the electric field is in the direction to move electrons away from the metal surface, but that no electrons can emerge from the surface, leaving a region of positive ions. An intense electric field connects these positive ions with electrons on the metal

surface. The positive ions will, of course, move toward and into the surface, becoming neutralized; however, we shall overestimate the potential jump in the boundary layer by assuming that the ions are immobile. If  $N_+$  is the density of positive ions, the electric field at the metal surface is (cgs electrostatic units)

$$E_s = 4\pi N_+ e d \quad (5-1)$$

The potential jump  $\delta V$  across the boundary layer is

$$\begin{aligned} \delta V &\approx \frac{1}{2} E_s d \\ &\approx 2\pi N_+ e d^2 \end{aligned} \quad (5-2)$$

The distance  $d$  is related to the electron mobility  $\mu$  and the electric field  $E$  in the air outside the boundary layer

$$d = \mu \int E dt \quad (5-3)$$

The electron mobility  $\mu$  is of the order

$$\mu \approx 10^6 \text{ cm/sec-esu} \quad (5-4)$$

In the example above

$$E \approx \frac{4500 \text{ volts}}{5 \text{ cm}} = 3 \text{ esu} \quad (5-5)$$

and

$$\begin{aligned} d &\approx 10^6 \frac{\text{cm}}{\text{sec-esu}} \times 3 \text{ esu} \times 2 \times 10^{-8} \text{ sec} \\ &\approx 0.06 \text{ cm.} \end{aligned} \quad (5-6)$$

An estimate of  $N_+$  is

$$N_+ \approx 6 \times 10^{11} \text{ ions/cm}^3 \quad (5-7)$$

We then find from Eq. (5-2)

$$\delta V \approx 6.5 \text{ esu} = 1950 \text{ volts} \quad (5-8)$$

If this voltage jump were small compared with the voltage on the antenna, then the effect of the boundary layer (and the absence of electron emission from the surface) would be negligible. In our case it is not quite negligible.

## DOCUMENT CONTROL DATA - R &amp; D

*(Security classification of title, body of abstract and indexing annotation must be entered when the overall report is classified)*

1. ORIGINATING ACTIVITY (Corporate author)

Los Alamos Nuclear Corporation

20. REPORT SECURITY CLASSIFICATION

Unclassified

25. GROUP

3. REPORT TITLE

Direct Interaction Effects in EMP (U)

4. DESCRIPTIVE NOTES (Type of report and inclusive dates)

Research Note

5. AUTHOR(S) (First name, middle initial, last name)

Conrad L. Longmire

6. REPORT DATE

8 January 1971

7a. TOTAL NO. OF PAGES

22

7b. NO. OF REFS

None

8a. CONTRACT OR GRANT NO.

DASAC1-69-C-0058-P001

9a. ORIGINATOR'S REPORT NUMBER(S)

LANC-N-12

b. PROJECT NO. NWER Code: H

c. Task &amp; Subtask Code: C040

9b. OTHER REPORT NO(S) (Any other numbers that may be assigned this report)

Work Unit Code: 04-Basic Contract

d. 11-Mod. #1

10. DISTRIBUTION STATEMENT

11. SUPPLEMENTARY NOTES

12. SPONSORING MILITARY ACTIVITY

Defense Atomic Support Agency

13. ABSTRACT

(U) Direct interaction effects are discussed for objects located in EMP source regions.



14. KEY WORDS	LINK A		LINK B		LINK C	
	ROLE	WT	ROLE	WT	ROLE	WT
Electromagnetic pulse (EMP) Direct interaction Compton current Compton charging Hardened antennas						