

Problem 4 (20 points total) ASM Charts.

We want to compute the next-state table from the ASM chart given below and implement the ASM chart. **Read the instructions very carefully.**

4(a) (3 points) For the ASM chart below, give:

- the state names,
- the binary assignment for each state, and
- the input variables.

4(b) (7 points) Use 4(a) to derive the state table for the ASM chart.

4(c) (10 points) Implement the state table using D Flip-Flops.

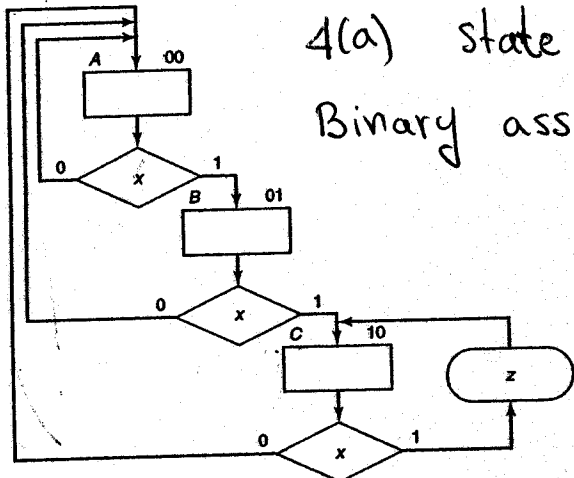

4(a) state names: A, B, C.

Binary assignment: A: 00
B: 01
C: 10

Input: X
Output: Z

4(b)
Current State
 Q_1, Q_0

Next State
x=0 x=1
 $Q_1^+, Q_0^+ / D_1, D_0$ ~~Q_1^+, Q_0^+ / D_1, D_0~~ $Q_1^+, Q_0^+ / D_1, D_0$

Output
x=0 x=1

| Current State Q_1, Q_0 | Next State | | Output | |
|-----------------------------|------------|-----|--------|-----|
| | x=0 | x=1 | x=0 | x=1 |
| 00 | 00 | 01 | 0 | 0 |
| 01 | 00 | 10 | 0 | 0 |
| 11 | xx | xx | x | x |
| 10 | 00 | 10 | 0 | 1 |

| | | |
|-------------------------------|---|---|
| | X | |
| | 0 | 1 |
| Q ₁ Q ₀ | | |
| 00 | 0 | 0 |
| 01 | 0 | 0 |
| 11 | x | x |
| 10 | 0 | 0 |

$$Q_1^+ = Q_0X + Q_1X$$

| | | |
|-------------------------------|---|---|
| | X | |
| | 0 | 1 |
| Q ₁ Q ₀ | | |
| 00 | 0 | 1 |
| 01 | 0 | 0 |
| 11 | x | x |
| 10 | 0 | 0 |

$$Q_0^+ = \bar{Q}_1 \bar{Q}_0 X$$

| | | |
|-------------------------------|---|---|
| | X | |
| | 0 | 1 |
| Q ₁ Q ₀ | | |
| 00 | 0 | 0 |
| 01 | 0 | 0 |
| 11 | x | x |
| 10 | 0 | 0 |

$$Z = Q_1 X$$

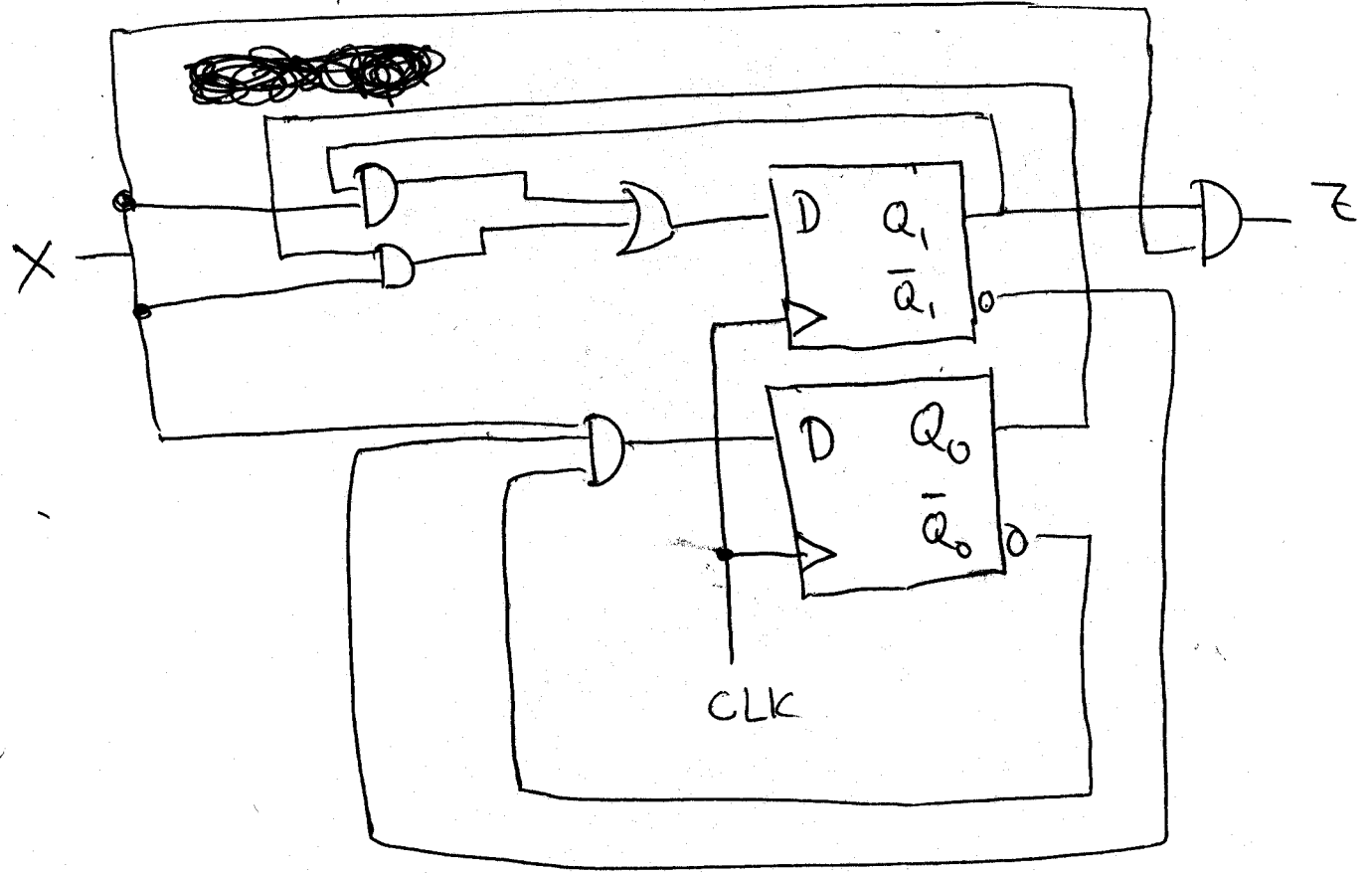

5.1
/

Problem 5 (20 points total)

Consider the standard multiplier circuit with its associated ASM chart shown in the Figure below. Suppose that initially: $B = (11)_2, Q = (11)_2$. Assume that all registers are 2 bits long.

5 (a) (2 points) In 4-bit unsigned arithmetic, what is the result of multiplying B by Q ?

5 (b) (18 points) Following the ASM Chart given below, indicate how the multiplication is carried out by the digital circuit. Does your result agree with 5(a)?

NB: To receive full credit, you must show the values of $A, B, C, C_{out}, P,$ and Q whenever they change.

5(a) $B \times Q = (1001)_2$

5(b) $B = (11)_2, Q = (11)_2$
 $C = 0, A \leftarrow 00, P \leftarrow 1.$

Q_0 is 1:
 $A \leftarrow A + B$
 $C \leftarrow C_{out}$ } $A = 11$
 $C_{out} = 0.$

$C \leftarrow 0, C \parallel A \parallel Q \leftarrow sr C \parallel A \parallel Q$
 $P \leftarrow P - 1$ gives:
 $C = 0, A = 01, Q = 11, P = 0$

check Z fails.

Q_0 is 1:

$A \leftarrow A + B$
 $C \leftarrow C_{out}$ } $A = 00, C_{out} = 1, C = 1$

$C \leftarrow 0, C \parallel A \parallel Q \leftarrow sr C \parallel A \parallel Q, P \leftarrow P - 1$

$\Rightarrow C = 0, A = 10, Q = 01, \Rightarrow$ check Z stops.

Answer: $AQ = (1001)_2$ ✓

